

# Satellite Executive BRIEFING

Vol. 14 No. 10 December 2021



Industry Trends, News Analysis, Market Intelligence and Opportunities

## The Most Significant Storylines of 2021

by Virgil Labrador

**W**e're finally near the end of 2021 and for most people, it couldn't come fast enough. It's been a very challenging year not only for the satellite industry but for pretty much the global economy.

As I've pointed out in several previous articles in this publication (*The Satellite Industry in a Post-Pandemic World*," September 2021 and *The Satellite Industry in the Time of Covid-19*, April 2020), some sectors may not have been impacted by the pandemic as others, but impacted nonetheless.

### Pandemics are Here to Stay

So as we look at the major storylines of 2021, perhaps the most significant of all is the ongoing global COVID-19 pandemic, now going on for nearly two years since the first cases were detected. As we go to press, the new Omicron variant merits serious concern, but there are



many positive developments that give cause for optimism, not the least of which is high vaccination rates in key countries and new anti-viral drugs that can prevent the more severe effects of the virus. For the satellite industry, most projections that it will fully recover from pre-pandemic levels in 2022 followed by further expansion thereafter. In the meantime, the industry still needs to cope with COVID-related issues such as supply chain disruptions and travel restrictions, among others. The world will never be the same again. The pandemic has changed the way we do business in profound ways. The key is not

*Continued on page 4*

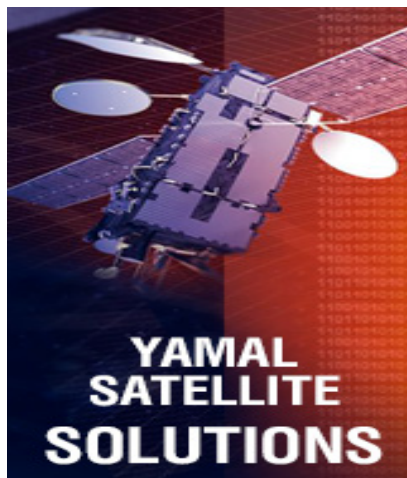

### What's Inside

From the Editor.....3



Country Profile: Taiwan  
by Aurélie Gillet.....8

Company Spotlight:  
*ND SATCOM: Flexibility, Agility and Resilience*.....16

Executive Spotlight:  
*Igor Kot, Dep. Sec.-General Gazprom Space Systems*.....20

*In Skynet We Trust*  
by Robert Bell.....24

Products Spotlight.....29

*A Year to Remember and A Year Ahead*  
by Martin Jarrold.....32

Mergers and Acquisitions.....35

Executive Moves.....37

Market Briefs.....39

Stock Index.....41

Ad Index.....42





**SPACEBRIDGE**

ALL THINGS CONNECTED

## CONNECTING PEOPLE TO THEIR MISSIONS



Cellular  
Backhaul

IIoT, ATM, SCADA,  
Oil & Gas

HTS Broadband  
Consumer &  
Enterprise

SATCOM On  
The Move

Government &  
Military

Managed  
Services

For over 30 years, SpaceBridge has striven to eliminate the digital divide by being an innovator, leader and trusted provider of bold solutions that keep people connected to their missions, everywhere.

We live on the cutting edge of what's possible, challenging ourselves, adapting to an ever-changing landscape while delivering ultra-reliable,

high-performance GEO and NGSO Extreme Broadband Gateways, VSAT Terminals, Modems and Services for mission critical applications.

As we venture even further, we invite you to join us as we aspire to make all things connected. Visit our website at [spacebridge.com](http://spacebridge.com) to learn how you can achieve greater connectivity.

**ALL THINGS CONNECTED**

[spacebridge.com](http://spacebridge.com) | [info@spacebridge.com](mailto:info@spacebridge.com) | +1.514.420.0045  
USA | CANADA | LATAM | BRAZIL | EMEA | APAC



## The Year in Review



As per our custom, for our final issue in 2021, we look at the most significant storylines that will impact the satellite industry moving forward. Note that we look at storylines and not just individual stories. This is in keeping with our mission to provide insights on opportunities and trends as opposed to simply reporting what happened.

Next month, for our first issue of the year, we will feature our annual Trends to Watch, expanding on some of the storylines that we identified for 2021 and more.

Also in the issue is a very comprehensive look at the Taiwanese Space Industry--a country that has not been known for its space activities. The findings of the article might surprise most.

We would also like to take this opportunity as we complete of 14th year in business and enter our 15th year in 2022 to thank all of our readers, subscribers, contributors and our advertisers who have supported us through the years. We would not have reached this point without your continued patronage and support. We hope we can count on your support in the years to come and we reaffirm our commitment to providing reliable, accurate and timely news, insights and actionable intelligence on the global satellite industry.

*Virgil Labrador*

Editor-in-Chief



## EDITORIAL

**Virgil Labrador**

Editor-in-Chief

virgil@satellitemarkets.com

**Peter I. Galace,  
Elisabeth Tweedie**  
Associate Editors

Contributing Editors:

North America:

**Robert Bell,  
Bruce Elbert, Dan Freyer,  
Lou Zacharilla**

Latin America:

**Bernardo Schneiderman**

Europe:

**Martin Jarrold (London)  
Omkar Nikam (Strassbourg)  
Hub Urlings (Amsterdam)  
Roxana Dunnette (Geneva)**

Asia-Pacific:

**Blaine Curcio (Hong Kong),  
Naoakira Kamiya (Tokyo),  
Riaz Lamak (India)**

## ADVERTISING

For Advertising enquiries send  
an e-mail to:  
info@satellitemarkets.com

Satellite Executive Briefing  
is published monthly by  
Synthesis Publications LLC  
and is available for free at  
www.satellitemarkets.com  
**SYNTHESIS PUBLICATIONS LLC**

1418 South Azusa Ave.  
Suite # 4174

West Covina CA 91791 USA

Phone: +1-626-931-6395

Fax +1-425-969-2654

E-mail:

info@satellitemarkets.com

©2008-2021.

No part of this publication may be  
reprinted or reproduced without prior  
written consent from the Publisher.

**Application Technology Strategy, L.L.C.**

**SATELLITE COMMUNICATIONS CONSULTING**

- System Architecture & Engineering
- Business Development
- Satellite Network Design
- Communications Payload and Ground Segment Design
- Due Diligence and M&A Support

Bruce Elbert, President  
Application Technology Strategy, L.L.C.

Office: +1 512 9430454  
Mobile: +1 310 9181728  
Fax: +1 512 9430455  
Web: www.applicationstrategy.com  
E-mail: bruce@applicationstrategy.com

## Satellite Industry...

from page 1

so much plan for a post-pandemic scenario, but instead learn from the experiences of the past two years and institute changes that will make your company pandemic-proof.

Here are other key storylines as I see it from 2021:

### Industry Consolidation

It's been a busy year for Mergers and Acquisitions (M&As) in the satellite industry. Just in the month of November there were eight major acquisitions. The biggest was the announced US\$ 7.3 Billion purchase of Inmarsat by Viasat. The combination of the two companies creates a powerhouse in key vertical markets such as mobile services, aeronautical and maritime, among others. The combined company will have spectrum licenses in Ka-, L-, and S-bands and a fleet of 19 satellites currently in service, with an additional 10 satellites planned in the next three years. Viasat previously acquired Rignet, a major service provider in the oil and gas business.

A key enabler of these M&As are the Special Purpose Acquisition Companies (SPACs) which have facilitated these M&As as well as funding startups like Momentus, Spire Global and BlackSky among others.

As a few companies get bigger and gain more market share, smaller companies will face a more competitive environment which leave them vulnerable for acquisition. So, look to see more M&A activity in 2022 as the industry consolidates.



**According to latest figures from the ITU an estimated 37 per cent of the world's population—or 2.9 billion people – have still never used the Internet. 97% of these are in developing countries..**

### Nearly 3 Billion Still Have No Internet Access

In November, the International Telecommunications Union (ITU) released a report that revealed that an estimated 37 per cent of the world's population—or 2.9 billion people—still never used the Internet. This bodes well for satellite companies, especially the new Non-Geostationary Orbit (NGSO) constellations who are aiming to bridge the digital divide. It also presents a challenge since 97% of those who have no access to the internet are in developing countries. What's significant about this figure is that hasn't changed much since the early 2000s, when a certain satellite startup called the "Other 3 Billion" aimed to close the gap.

Some satellite operators have actually made it their mission to connect the unconnected. Satellite

operator Kacific has made some inroads in the Asia-Pacific region with their all Ka-band satellite Kacific-1 and another satellite planned in the next three years. But with nearly three billion unconnected, clearly much more needs to be done to bridge the digital divide,

### New Technologies

In April this year, A seven-company consortium led by Airbus Defense and Space announced a plan for an in-orbit satellite factory that will assemble a satellite in space. This manufacturing in space concept follows many other innovations introduced in the last few years such as in-orbit servicing, software-defined satellites, among others that will fundamentally change the way satellites are manufactured, launched and operated.





[www.stn.eu](http://www.stn.eu)

[@ sales@stn.eu](mailto:sales@stn.eu)



**STN**

***A FULL RANGE OF HOSTING SERVICES FOR  
LEO / MEO CONSTELLATIONS  
TT&C SERVERS ANTENNAS***



## Space Security

On November 14, Russia used an anti-satellite weapon (ASAT) to destroy a retired satellite, Cosmos 1408. The event caused over 1,500 trackable pieces of debris in space which poses a hazard to existing orbital assets for decades to come. The destruction of the satellite, which was reminiscent of a similar operation by China in 2007 with one of their own satellites, was widely condemned internationally. Blowing up a satellite poses a serious security risk for existing satellites as well as the concern for the growing problem of space debris.

Space is increasingly getting crowded. In 2019, there were around 2,200 operational satellites. In 2020 alone, some 1,300 satellites were launched and another 1,400 so far in 2021--mostly Low Earth Orbit (LEO) satellites. This means that the number of satellites in orbit has more than doubled in the just the last two years with thousands upon thousands more launches planned in the coming years.

As satellite play a very vital role in societies where many essential services depend on it, their security and safety should be a primary concern. International condemnation of ASAT activities is not enough. There should be serious sanctions against ASAT activities or better yet a permanent ban.

## Space Tourism Takes Off

On July 11, 2021, Virgin Galactic launched its first commercial sub-orbital flight with Billionaire founder Richard Branson and five other passengers on board. This was followed by Blue Origin's successful flight



**After many years of eager anticipation, Virgin Galactic finally launched its first commercial sub-orbital flight on July 11, 2021 with founder Richard Branson and five other passengers.**

with Billionaire Jeff Bezos just nine days later. SpaceX, meanwhile sent four civilians on a three-day orbital mission in September. By the end of the year, there were several other sub-orbital flights that followed, making it seem that it will be a regular occurrence in the coming years.

The high profile space flights carrying media-savvy Billionaires generated widespread interest in space among the general public. Space

has always been cool, but it's even hotter now as it fills the headlines with the increasing competition among the Billionaires to one-up each other in space. This increased interest can only provide dividends such as more people getting into the space industry as well as influx of investments in the sector.

It certainly is an interesting time to be in the space and satellite industry. 



**Virgil Labrador** is the Editor-in-Chief of Los Angeles, California-based Satellite Markets and Research which publishes [www.satellitemarkets.com](http://www.satellitemarkets.com), a web portal on the satellite industry, the monthly Satellite Executive Briefing magazine and occasional industry reports called MarketBriefs. Virgil is one of the few trade journalists who has a proven track record working in the commercial satellite industry. He worked as a senior executive for a teleport in Singapore, the Asia Broadcast Center, then-owned by the US broadcasting company CBS. He has co-authored two books on the history of satellite communications and satellite technology. He holds a Master's in Communications Management from the University of Southern California (USC). He can be reached at [virgil@satellitemarkets.com](mailto:virgil@satellitemarkets.com)





عرب سات  
ARABSAT



عالمنا... عالمكم.  
Our world Your world

**Our world. Better,  
more reliable, more reachable  
and more efficient. Your world.**



**30.5° EAST  
Arabsat 6A**

The latest addition  
to our fleet.

 /Arabsat  @Arabsat  /Arabsat

[www.arabsat.com](http://www.arabsat.com)

# Taiwan: A Serious Up-and-Coming Player in the Space Industry

by **Aur lie Gillet**

**T**aiwan, a small island in the Pacific Ocean with a population of 23.5 million, is not the first place that comes to mind when thinking of space powers. With a historically limited domestic space sector, Taiwan's space ambitions have been limited to a few technologically impressive, but still niche missions, with this despite an economy that has developed several world-leading high-tech sectors, and a world-leading supply chain for certain critical components.

This trend of limited space ambitions has been changing, however, and Taiwan may soon become a key player in the global space ecosystem. The unique development model applied to the Taiwanese space industry has already seen tangible positive consequences, with selected electronics manufacturers having become SpaceX suppliers for example; it is also very likely to enable Taiwanese electronics manufacturers to move up the scale of the global space industrial chain in the near future. Taiwanese commercial space companies, while only emerging, may also benefit from enhanced state support in view of Taiwan's political will to carve a niche in an up-coming industry - despite existing political tensions with China, especially when it comes to the launch sector.

## Ambivalent Space Ambitions in a Tense Political Climate

Taiwan's space programme began in 1991 with the

creation of the National Space Organization (NSPO). This is much later than China and Japan, who launched their space programmes in the 1950s, yet coincides with the launch of fellow Dragon economies' space programs in South Korea and Singapore, in the late 1980s-early 1990s. With a history of only 30 years, the Taiwanese space program is arguably still nascent. If significant progress has been made in Earth Observation, remote sensing and space science, the Taiwanese launch capabilities are lagging both global and regional standards.

The complexity of Taiwan's political context is reflected in its ambivalent motivations within the space sector. In particular, the nature of Taiwan's governance is a highly contentious issue in the context of cross-strait relations: if the island is de facto an autonomously governed territory, it is not officially recognised as an independent state under international law and its formal independence constitutes a red line for the Chinese Communist Party. In the preamble of China's 1982 Constitution, Taiwan is

defined as being "part of the sacred territory of the People's Republic of China."<sup>1</sup> The latter has even dedicated a Department of its Ministry of Foreign Affairs to Hong Kong, Macau and Taiwan affairs<sup>2</sup>.

The tense cross-strait political context has had an impact on Taiwan's space program. Indeed, Taiwan has been reluctant to develop launch capabilities due





to the dual use of the required technology, rocket technology being easily transformable into ballistic missiles or other military technology. It is suspected that the United States themselves, primary military ally of the island, have pushed Taiwan to refrain from developing such capability on the grounds that it could potentially give China a reason for intensifying military actions around the island<sup>3</sup>.

Until recently, Taiwan's efforts have hence been focused on developing satellite payload capacities, delegating launch to foreign companies, and have been led primarily by governmental, traditional actors. Yet, the past few years have seen the development of a commercial space sector in Taiwan, with several commercial companies being created, including commercial launch companies. The island may also be able to leverage its strengths in advanced manufacturing and semiconductors: if electronic components Made in Taiwan were to become as indispensable to the space sector as it is to the semiconductor sector, the island would have an immense role to play in the space industry.

### Taiwan's Government Space Program: From Technology Transfer to Autonomy

Tasked with overseeing the implementation of the Taiwanese space program, the NSPO has been driving the development of space technology and industry throughout the three phases of the programme. If the first and second phases were focused on building up basic capabilities through technological transfer, the third phase aims at the industrialization of space technology and at achieving greater autonomy in the sector through leveraging Taiwan's industrial base.

#### Phase 1: Building up Space Technology and Fostering Indigenous Capabilities

The first phase, which lasted from 1991 to 2006 and consisted mainly in three missions, was dedicated to building Taiwan's capacities in satellite manufacturing, including bus and payloads, through technology transfers with the US (FORMOSAT-1 and -3) and France (FORMOSAT-2),

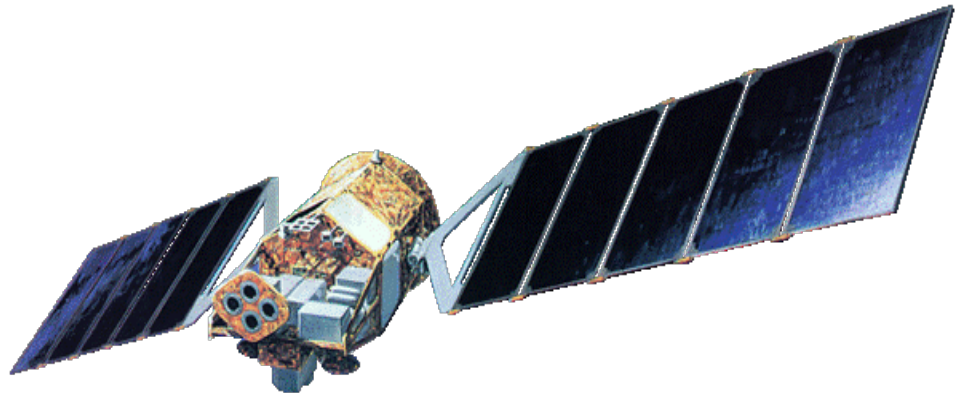

### FORMOSAT-1

for a total budget of NT\$19.7 Billion (US\$638 million)<sup>4</sup>.

FORMOSAT-1, a 400kg low-earth-orbit scientific experimental satellite, was almost entirely designed and built by the US company TRW (Space & Electronics Group); as part of the technology transfer agreement, a group of NSPO engineers received training in satellite "design, testing, and operation/control"<sup>5</sup>. Most payloads were also jointly developed: while the Ionospheric Plasma and Electrodynamics Instrument (IPEI) was jointly built by the University of Texas at Dallas and Taiwan's National Central University, the Experimental Communication Payload (ECP) was developed by Microelectronics Technology Inc., Trans System Inc. (two Taiwanese commercial companies) and Japan's NEC Corporation. The same scheme was employed for FORMOSAT-2. The bus of the 700kg FORMOSAT-2 remote sensing satellite was built by Astrium SAS, a European leader in the aerospace manufacturing industry (of which Airbus Defense and Space is the successor since 2013) - with participation of Taiwanese engineers. Astrium SAS also built the Remote Sensing Instrument (RSI), while the other payload, the Imager of Sprites and Upper Atmospheric Lightning (ISUAL), was jointly developed by four institutions: the NSPO, Taiwan's National Cheng Kung University, the University of California at Berkeley and Japan's Tohoku University.

The last mission of phase 1 of the Taiwanese space program consisted of jointly building a LEO constellation of six 60kg Earth Observation microsattellites, the FORMOSAT-3/COSMIC constellation, with the United States. The US\$100M project, of which Taiwan covered 80%<sup>6</sup>, was led by the NSPO and the US' University Corporation for Atmospheric Research (UCAR), and was supported by other institutions<sup>7</sup>. The satellite platform



## TV CHANNEL OWNER, WE CAN HELP YOU WITH EVERYTHING!

- Satellite broadcasting
- Playout management
  - Cloud services
- Disaster recovery for tv channels
- Occasional use delivery of sports and events
  - Fiber and IP delivery
- OTT and online services
- Content aggregation
  - EPG creation

For more information:  
**[sales@ikomg.com](mailto:sales@ikomg.com)**

[www.ikomg.com](http://www.ikomg.com)

iKO Media Group is a boutique end-to-end media service partner for broadcasters and content owners. We provide tailor-made solutions focused on our customer needs. A leading and trusted partner to hundreds of global and local networks, iKONG is identified with expert knowledge, dedicated service and professionalism.



was the product of joint efforts between Orbital Sciences Corporation (US) and the NSPO, with the integration and testing performed by the latter<sup>8</sup>. All three main payloads were designed and built by US companies.

For each of those missions, several Taiwanese companies were involved in the process so as to build indigenous capacities. Among them, Victory Industrial Corp., Acer Sertek Inc. and Shihlin Electric & Engineering Corp. participated in all three missions; the first by providing S-band antennas and other communications equipment, the second by providing electronic devices such as on-board computers (OBC), and the third by providing components for the solar panels<sup>9</sup>. Other indigenous companies included Tatung System Technologies Corp., Aerospace Industrial Development Corp., Taiwan Aerospace Corp. and others. The objective of phase 1 was for Taiwan to acquire the basic technology and expertise to subsequently develop its own satellites through cooperation with US, French and other international institutions and companies. It also sought to foster the development of indigenous capabilities, through involving both research centers and commercial companies (mainly involved in the electronics industry) in each mission.

The second phase of the Taiwanese space program, extending from 2004 to 2018 for a budget of NT\$25.9 Billion (US\$800 million), marked a turning point - of which the significance was yet attenuated by political factors.

The FORMOSAT-5 mission, aimed at the development of the 450kg eponymous satellite, was the first to be indigenously developed and manufactured - as noted on the NSPO website, "FORMOSAT-5 is the first space program that National Space Organization (NSPO) takes full responsibility for the complete satellite system engineering design including payload(s)"<sup>10</sup>. The success of the mission, completed by the launch of the remote sensing satellite from the US in 2017, can be qualified as a technological feat: Taiwan's capacity to indigenously develop such technology only 25 to 26 years after the very beginning of its space program is indeed rather impressive.

In contrast, the FORMOSAT-7/COSMIC-2 mission was not conducted by Taiwan alone, but in cooperation with the US, and enabled Taiwan to further strengthen its capabilities in spacecraft development, design and integration of mission systems, as well as constellation mission operations<sup>11</sup>. Besides those two missions, the NSPO signed contracts for the development of three cubesats: IDEASSat to be developed by the National Central University (NCU), YUSAT by the Department of Trans-

portation Science of National Taiwan Ocean University (NTOU) with the participation of MoGaMe Mobile Entertainment, and NutSat by the National Formosa University<sup>12</sup>. If the first two have been successfully launched in January 2021, the latter has yet to reach orbit<sup>13</sup>.

It is important to note that such developments concern only satellite technology. Originally, the FORMOSAT-6 mission did plan for the indigenous development of launch technology: the FORMOSAT-6 satellite, expected to be developed by NSPO and Taiwanese universities, was indeed supposed to be launched by a Taiwan Small Launch Vehicle (TSLV) designed by the Chung-Shan Institute of Science and Technology (CSIST) - which used to be under the island's Ministry of National Defense's Armaments Bureau, responsible for the development of weapons and dual-use technologies. Yet the project was aborted, most likely because of political pressure from the US, concerned about China's reactions vis-a-vis the development of dual-use technology<sup>14</sup>.

### Phase 3: Leveraging Taiwan's Unique Strengths to Industrialise Space Technology

The third phase of the Taiwanese space program distinguishes itself from the two other ones by its scale and ambitions. With a budget of NT\$25.1Billion (US\$814 million) to be spent from 2019 to 2028 (over 10 years, instead of 15 years for the two previous stages), phase 3 plans for the development of a constellation of six prototype high-resolution optical remote sensing satellites (FORMOSAT-8), two ultra-high resolution smart optics remote sensing satellites as well as two synthetic aperture radar (SAR) satellites<sup>15</sup>. As far as the FORMOSAT-8 mission is concerned, Taiwan will rely on its domestic industry as well as on the technology previously acquired to indigenously design and manufacture each of the six satellites. If the overwhelming focus on Earth Observation technology constitutes a continuation with the two previous phases, other projects mark expanding ambitions.

Taiwan indeed plans to develop its own LEO constellation as per the Beyond 5G program (B5G), to which NT\$4 Bil. (US\$141 million) will be dedicated. The first communications satellite is to be launched by 2025, after which six other will follow<sup>16</sup>. The project is led by Taiwan's Industrial Technology Research Institute (ITRI) - famous for having incubated key tech companies such as TSMC<sup>17</sup>-with the help of 18 local companies, "including prominent producers of antennas, radio frequency com-

ponents, mobile phone chips and network communication equipment”<sup>18</sup>. The objective of this programme is highly strategic: through involving indigenous companies in a programme of greater scale, Taiwan seeks to further help the latter develop and test key technologies (including components, modules and subsystems<sup>19</sup>), so as to boost their competitiveness and enable them to integrate the global space industry supply chain.

Phase 3 is also oriented towards the Moon. Taiwan seeks to develop, with foreign partners, a satellite which would be placed in orbit around the Moon<sup>20</sup>. Such a project illustrates Taiwan’s ability to cooperate with other countries on an equal basis - and shows the extent to which the Taiwanese space program has progressed over the course of 30 years, at least as far as satellite technology is concerned.

### **Taiwan’s Space Development Model: Early Successes, Great Economic Potential and Remaining Challenges**

Throughout the three phases of Taiwan’s space pro-

gram, the Taiwanese government sought to enable selected Taiwanese commercial companies of the electronics industry - most of which are original equipment manufacturers (OEM) - to adapt their technology to space-grade standards and to test their products in orbit.

In addition to the aforementioned missions of phases 1, 2 and 3, the 2001-2002 YamSat programme - under which two pico satellites were developed by universities and research institutes, with key components built by commercial companies - also aimed at providing such an opportunity. Unfortunately, neither of the two satellites were launched, hence no in-orbit verification has been possible. The missions of the third phase of Taiwan’s space programme are most promising for technological verification: no less than 13 satellites are planned to be developed, with at least 8 to be launched by 2028. A plethora of companies will hence be able to test their technology in-orbit. It is important to note that few commercial companies have led space projects themselves: non-commercial, traditional actors were the primary leader in most projects so far - at least as far as satellite-related projects are concerned.



**JONSA®**

www.jonsa.com.tw  
saccount@jonsa.com.tw

**Link Jonsa VSAT Antenna Cover Your Life**





Based on aforementioned factors, it may fair to assess that Taiwan has developed a unique model of development for its space industry: one in which the focus is not on fostering indigenous commercial space companies, but one in which traditional actors take the lead in space operations to help companies in the electronics industry develop top-quality space-grade components - thereby leveraging the island's strategic advantages. Such a model of development may very well illustrate the legacy of the developmental state model. Admittedly, a few commercial space companies taking the lead are emerging in Taiwan, but they do not seem to constitute the priority of the Taiwanese government - at least for the time being. Their potential, which is certainly not insignificant, will be explored in due time.

### Initial Space Industry Successes from Taiwan's Development Model

Taiwan's development model for its space industry seems to have been rather successful in enabling commercial companies to integrate the global space industry supply chain. Indeed, one direct consequence of the aforementioned programs is the ability of Taiwan's electronics companies to supply products to the most advanced commercial space company of the 21st century: SpaceX.

In an interview with the Taiwanese Central News Agency (CNA), the deputy director general of NSPO, Yu Shiann-jeng, revealed that "around a dozen Taiwanese companies... are currently providing components and ground-based reception equipment for SpaceX."<sup>21</sup> Such companies include Microelectronics Technology Inc., a ~US\$500 million market cap company focusing on communications equipment manufacturing such as Ku-band BUC, 3W Ka-band transceiver and other VSAT-related products. It notably developed FORMOSAT-1's Experimental Communication Payload (ECP). Another example is WIN Semiconductors Corp., a ~US\$5 Billion market cap company with top-line revenues of around US\$1 Bil. in 2020. The company focuses on Gallium Arsenide (GaAs), a key component of semiconductors, and according to its website, its semiconductor application portfolio includes VSATs<sup>22</sup>. A third company is Kinpo Electronics, an electronics company focusing on semiconductors, communication equipment, robotics and other electronic products, with a



**One of several Taiwanese satellite ground equipment companies is Jonsa Technologies, an antenna manufacturer with a monthly production capability of over one million units.**

market cap of around US\$700 million. Other suppliers include Gongin Precision Ind. Co. Ltd, Chicony Power Technology Co., Elite Material Co. Ltd., Compeq Manufacturing Co. Ltd., as well as Shenmao Technology Inc. Although not much is publicly known about the specific types of equipment supplied, broad categories include semiconductors, as well as VSATs and ground terminals equipment and other precision electronic components.

Such a success bodes very well for Taiwan, especially considering that "with maturer technology and experience in the future, Taiwanese companies could extend their reach to provide more comprehensive modules with better added value<sup>23</sup>," as argued by Yu Shiann-jeng in an interview with the CNA. Taiwan may hence be on the verge of reaping increased economic benefits from its space industrial activities. Opportunities and challenges for emerging commercial space companies

Beyond commercial companies of the electronics sector manufacturing space-grade components, a number of space-focused commercial companies are taking the lead in space projects, and are exploiting the opportunities offered by the Taiwanese industrial ecosystem. Yet, some challenges remain.

A promising sector of commercial activity lies in the launch vertical, as illustrated by the commercial launch company tiSpace. The government project to develop a Small Launch Vehicle rocket was cancelled in 2016, and launch technology is now being developed by a commercial actor, tiSpace (founded the same year). The

company's products include the Hapith-5 rocket, still under development, as well as the Hapith-I rocket. The maiden launch of the latter, initially scheduled in 2019, has been pushed back several times due to the difficulty to find a launch site; when it finally took place in September 2021, the rocket unfortunately failed to leave the ground. tiSpace has recently declared that it would try again before the end of the year<sup>24</sup>. It is interesting to note that tiSpace's hybrid rockets are 100% made in Taiwan, which highlights the positive synergies within the Taiwanese industrial ecosystem. The reduced costs resulting from such synergies may soon lead to the emergence of more commercial space companies on the island, seeking to exploit the advantages offered by Taiwan's industrial base at a competitive price.

There is also a thriving ground equipment sector in Taiwan which produces antennas and other satellite equipment. One such company is Jonsa, which manufactures high-quality parabolic dishes for DTH, VSAT, WISP, Flyaway, and Maritime applications. The company has a monthly production capability of over one million units.

Commercial space companies also seem to be facing funding and start-up ecosystem challenges in Taiwan, as is suggested by the relocation of Odysseus Space's headquarters from Taiwan to Luxembourg. Founded in 2016 by three French engineers in Taiwan, the company moved its headquarters to Luxembourg in January 2019 "to join an ecosystem of over 50 firms developing space-related technologies", following an invitation by the LSA after having won the Space Resources Challenge organised by ESA in 2018, along with 500,000€ (US\$570,000) as a reward<sup>25</sup>. Its centre of activity seems to have shifted from Taiwan to Luxembourg, as it is developing "laser communication terminals for LEO applications" and technology for "autonomous navigation to the Moon and beyond" under ESA/LSA (European Space Agency/Luxembourg Space Agency) contracts<sup>26</sup>. Such a shift may reveal a potential lack of dynamism of the Taiwanese space industry and perhaps a lack of funding opportunities for commercial space companies. That being



**Hapith-I rocket at the Whaler's Way Orbital Launch Complex** (Source: InDaily)

said, since Odysseus Space has maintained activities in Taiwan, it will possibly use the strengths of the Taiwanese industrial base to manufacture its future products.

### **Moving Forward: What to Expect in the Coming Years**

Moving forward, Taiwan does have the potential to become a key player in the space supply chain - and definitely has the political will to do so. At her second term's inaugural speech in May 2020, Tsai Ing-wen indeed defined the space industry as one of the Six Core Strategic Industries<sup>27</sup>, before asserting that "Taiwan should use its advantages in the semiconductor sector to occupy a spot in the space industry supply chain" in September 2021<sup>28</sup>. The adoption of Taiwan's first space law by the Legislative Yuan on May 31 proves the island's determination to put increasing effort and resources into industrialising space technology.

Commercial space companies are likely to benefit from stronger government support. As far as the commercial launch sector is concerned, it is a promising, emerging industry facing serious challenges. For tiSpace, the only commercial company developing launch technology in Taiwan to date, the next few months will tell us whether its efforts to develop the Hapith-I have been fruitful, or whether more research is necessary. For the launch sector generally, political tensions with China, as well as the weight of US poli-



cy orientation on the island's decisions, may lead to other hiccups in the development of launch vehicles.

Given Taiwan's strong industrial basis and leadership in the electronics sector, with TSMC being a global leader in the semiconductor sector (among other things), the island has the potential to carve a niche and become a key actor in the space industry through leveraging its existing strengths to move up the scale in the global space industrial chain. The strategic dimension of Taiwan's industrial base may even constitute sufficient ground to avoid a war on the island's territory at all cost.



## Notes

<sup>1</sup>Constitution of the People's Republic of China, 1982.

<sup>2</sup>The Department of Hong Kong, Macao and Taiwan Affairs, accessed 23 September 2021, [https://www.fmprc.gov.cn/mfa\\_eng/wjb\\_663304/zzjg\\_663340/gats\\_665294/](https://www.fmprc.gov.cn/mfa_eng/wjb_663304/zzjg_663340/gats_665294/).

<sup>3</sup>K. g Chan, 'Taiwan Kills Rocket Plan "amid US Concerns"', Asia Times, 18 July 2019,

<sup>4</sup><https://www.rti.org.tw/news/view/id/2024540>.

<sup>5</sup>Herbert J. Kramer, Observation of the Earth and Its Environment: Survey of Missions and Sensors (Springer Science & Business Media, 2002), 499.

<sup>6</sup>COSMIC Turns 10: Microsatellites Reveal Atmospheric Properties in 3D, NCAR & UCAR News, <https://news.ucar.edu/19848/cosmic-turns-10-microsatellites-reveal-atmospheric-properties-3d>.

<sup>7</sup>Kramer, Observation of the Earth and Its Environment, 229.

<sup>8</sup>Kramer, 230.

<sup>9</sup>FORMOSAT-1 - National Space Organization, accessed 14 October 2021, [https://history\\_prog.php?c=20030403&ln=en](https://history_prog.php?c=20030403&ln=en); 'FORMOSAT-2 - National Space Organization', [https://history\\_prog.php?c=20030402&ln=en](https://history_prog.php?c=20030402&ln=en); 'FORMOSAT-3 - National Space Organization', accessed 15 October 2021, [https://history\\_prog.php?c=20030401&ln=en](https://history_prog.php?c=20030401&ln=en).

<sup>10</sup>'FORMOSAT-5 - National Space Organization', accessed 11 October 2021, <https://www.nspo.narl.org.tw/inprogress.php?c=20030301&ln=en>.

<sup>11</sup>'FORMOSAT-7 - National Space Organization', accessed 11 October 2021, <https://inprogress.php?c=20022301&ln=en>.

<sup>12</sup>Hsin-Chia (Albert) Lin and Jyh-Ching Juang, 'Space Education Activities and CubeSat Programs in Taiwan'.

<sup>13</sup>'National Central University successfully received and decoded the', [https://news\\_view.php?c=210209001&ln=en](https://news_view.php?c=210209001&ln=en).

<sup>14</sup>Michael Cole, 'US Qualms May Have Nixed Taiwan Space Launch Program', Taipei Times, 19 December 2011, Jann-Yenq Liu et al., 'The Fast Development of Solar Terrestrial Sciences in Taiwan', Geoscience Letters 3, no. 1 (23 June 2016): 18, <https://doi.org/10.1186/s40562-016-0049-0>.

<sup>15</sup>'Ministry Announces Third Phase of Space Program', Taipei Times 14 February 2019, <https://www.taipetimes.com/News/taiwan/archives/2019/02/14/2003709706>.

<sup>16</sup>'Ministry Planning Low-Orbit Satellite Launch in 2025', 14 January 2021, <https://www.taipetimes.com/News/taiwan/archives/2021/01/14/2003750557>.

<sup>17</sup>'ITRI Overview-About Us', Industrial Technology Research Institute, accessed 26 October 2021, <https://www.itri.org.tw/english/ListStyle.aspx?DisplayStyle=20&SiteID=1&M-mmID=617731521661672477>.

<sup>18</sup>Taiwan News, 'Taiwan's ITRI to Build Trailblazing Domestic 5G Ecosystem', Taiwan News, 24 July 2019, <https://www.taiwannews.com.tw/en/news/3751124>.

<sup>19</sup>'Ministry Planning Low-Orbit Satellite Launch in 2025'.

<sup>20</sup>'Ministry Announces Third Phase of Space Program'.

<sup>21</sup>'Taiwan eyeing business opportunities in space industry', CNA, 17 July 2021, <https://focustaiwan.tw/scitech/202107170012>.

<sup>22</sup>'WIN Semiconductors - Leading Global Communication', accessed 27 October 2021, <https://www.winfoundry.com/en-US/>.

<sup>23</sup>'Taiwan eyeing business opportunities in space industry'.

<sup>24</sup>'Taiwan's TiSPACE to Try Again after Launch Attempt Ends in Flames', SpaceNews, 7 October 2021.

<sup>25</sup>'Deep Space Tech Firm Odysseus Relocating HQ from Taiwan to Luxembourg', Taiwan News, 6 November 2018, <https://www.taiwannews.com.tw/en/news/3568963>.

<sup>26</sup>'Odysseus Space', accessed 2 November 2021, <https://odysseus.space/#technologies>.

<sup>27</sup>'Inaugural Address of ROC 15th-Term President Tsai Ing-Wen', <https://english.president.gov.tw/News/6004>.

<sup>28</sup>Taiwan News, 'President Wants Taiwan to Join Global Space Industry Supply Chain', Taiwan News, 14 September 2021, <https://www.taiwannews.com.tw/en/news/4286675>.



**Aurélie Gillet** is a space industry analyst with Orbital Gateway Consulting based in Hong Kong. She is a masteral candidate at King's College, London and holds a bachelor's

degree in Social Sciences from the University of Hong Kong. She can be reached at:

[aurelie@orbitalgatewayconsulting.com](mailto:aurelie@orbitalgatewayconsulting.com)

## ND SATCOM: Flexibility, Agility and Resilience

**P**andemic-related crises and challenges continued to reverberate across the world in 2021, and industries continued to adapt to varying external factors ranging from unprecedented supply chain interruptions to the multitude of changing governmental regulations affecting borders and commerce. In addition, the ongoing safety and health measures for both employees and customers were universal issues.

The enormous degree of flexibility, agility, and commitment required – under the circumstances – defined those companies that will conclude the year with an improved bottom line. ND SATCOM was amongst them. Its stable leadership prevailed as it pursued the path of investment in new technologies and new market opportunities. As well, ND SATCOM advanced its digitalisation plan by securely connecting its worldwide network of offices, partners, and customers with the company headquarters.

ND SATCOM launched a variety of innovative products that exceeded customer expectations and extended its outstanding SKYWAN 5G solution with a new and very exciting military application. In addition, ND SATCOM countered the pandemic's effects on traditional B2B interactions (trade fairs and direct customer visits) by introducing new communication channels for its partners and customers via social media and its own interactive platform, which securely hosts live meetings, demos, and trainings. ND SATCOM's virtual activities successfully closed the pandemic-driven distance and learning gaps by providing the forum for group meetings and one-on-one sessions

customers requested.

"Through resilience, dedication, and creativity, the entire ND SATCOM family came together to support its global network and achieve its 2021 goals," said ND SATCOM's CEO Alexander Müller-Gastell.

In 2021, ND SATCOM's sales volume showed a very positive development, far exceeding the planned revenue with the defence market as a strong driver. Growth was also sustained by the successful installation of SKYWAN 5G solution across multiple governmental customers worldwide as the core component within most projects. The human factor was integral to this performance with the entire team's outstanding experience and customer engagement reflecting the brand quality and reliability customers expect.

ND SATCOM has been very successful in positioning the SKYWAN 5G as the standard modem and core element among defence customers. Its performance has proven itself time and again, and the extremely flexible network topology and sophisticated network management are strong selling points.

ND SATCOM extended support of tactical applications for military customers by developing customised and rugged versions of the modem with regard to size and weight but also to encryption. With the fast-growing SatCom-On-The-Move market for defence, ND SATCOM is now ready and expe-



**ND SATCOM CEO  
Alexander Müller-Gastell**

rienced to serve customer needs in this field after completing extensive tests with different antennas together with a German research institute.

ND SATCOM continues to grow globally: in Asia, close cooperation with government key players convinced the end customers to order complex networks with stringent requirements for resilience and geo-diversity. The combination of mesh network capabilities with additional geo-redundant DVB-S2 out-bounds to interconnect sites was already adopted for several networks and more will follow. To support this growth ND SATCOM increased its regional expert team in several Asian countries. A "multi-station





INSTALLING  
RELIABILITY

[www.ndsatcom.com](http://www.ndsatcom.com)

# MULTI-BAND FLYAWAY TERMINAL MFT 1500 +++ SEVERE STORMS ++ GALE-FORCE WINDS +++ READY TO COMMUNICATE ANYTIME

Send and receive where other systems have already given up. Discover the new ND SATCOM Multi-Band FlyAway Terminal **MFT 1500** with integrated SKYWAN technology, which is revolutionizing the market with its unique robust design. Whether you are experiencing severe storms or gale conditions, this terminal is extremely reliable, ready for immediate action, and raises the bar worldwide in terms of communication security. Plus, its light and durable components enable easy transport and a long product life.

 Making Missions Possible

network in a 4U rack” was used to demonstrate SKYWAN technology in both theoretical courses and real operations. It can be shipped worldwide to support partners and customers on all continents.

ND SATCOM not only builds excellent components “Made in Germany”, it designs and delivers turnkey solutions that comprise complete networks.

In 2021, ND SATCOM won a huge project in the Americas to deliver SKYWAN 5G modems with release 2.0 that comes with True-Mesh ACM. The key factors for success were not only the modem and other components developed in-house, but also the strong local support and the customer’s trust in ND SATCOM’s service organisation during the solution’s lifetime.

At the German AFCEA conference in Bonn in September 2021, ND SATCOM presented the new Multi-band FlyAway Terminal (MFT) family and showed the X-band version of the MFT 1500 at its booth. One advantage that sets this new terminal apart is its operational wind resiliency: it can withstand and function in very high wind speeds and during severe storms. Customers value the proven high reliability and security that SKYWAN represents.

The evolution of ND SATCOM’s flagship product, the SKYWAN 5G modem, was of course one of the main core tasks of the R&D team. After the SKYWAN release 2.0 launched in 2020, an updated and extended version of the software was released end of 2021. Main new features are a customisable dashboard for the network management software (NMS) and the support of the MFT. As always, the updated software is now available for all platforms featuring backward compatibility with the SKYWAN release 2.0.

Two more launches took place

In September 2021, ND SATCOM launched its new Multi-band FlyAway Terminal, MFT-1500. View a video demonstration of the unique features of the terminal at:

[satellitemarkets.com/ndsatcom-mft-1500-cabsat-2021](https://satellitemarkets.com/ndsatcom-mft-1500-cabsat-2021)

in 2021: the HPA 4-Series, the latest version of high power amplifiers, marks the next generation of TWTA with its power and performance. Highlights include improved usability through a new intuitive WebUI and simplified Automatic Level Control (ALC), enhanced performance through reduced intermodulation and halved warm-up time, easy maintenance through firmware upgrades via LAN, and consistent M&C and dimensions to its legacy series. The other launch, the redundancy controller RCU 6000 released in April 2021, covers the range from single HPA control up to the management of six active transmission chains. It offers a highly intuitive user interface to manage all functionalities: various base band encoders, modulator to upconverters, and multiple HPAs with all switch elements. The RCU 6000’s exceptional quality and higher temperature range are what customers seek for failsafe operations.

Usability, performance, and monitoring highlights include 6 waveguide switch interfaces, ultra-fast multi-core CPU and 8 fast Ethernet ports, and dual 1-Gbit/s LAN for remote access.

ND SATCOM developed and built a live demonstrator together with a German governmental customer: the installed secure network with ad-hoc WIFI technology to seamlessly interconnect police stations with police cars or other ter-



minals proved itself with superior performance and stability. The same core technology was used to the customer’s utmost satisfaction by monitoring a sensitive operation with video data from a helicopter.

ND SATCOM started in 2021 with a new activity to enhance the core product SKYWAN 5G by enabling proprietary waveforms for special platforms to integrate with Ku and Ka-band antenna subsystems for high speed communication links. After many hours of simulations, this new market will be addressed in 2022. Also, ND SATCOM will complete its Multi-band FlyAway Terminal (MFT family) to cover the mid-size range from 1.5m up to 2.4m with many RF and power combinations. The MFTs will be verified to comply the MIL standards. On the one hand, the tight integration of the SKYWAN modem will provide perfect extension of existing VSAT networks. On the other hand, totally new scenarios and customer problems will be addressed. With the recently launched HPA 4-series and the new RCU 6000 controllers, the next generation of uplink components have been successfully brought to the market to continue the long and ongoing success story of ND SATCOM in the field of uplink devices. Finally, the next generation of the antenna control units - the ACU 6000 – will be ready and launched in 2022 to complete the portfolio. 





Russian Satellite  
Communications Company

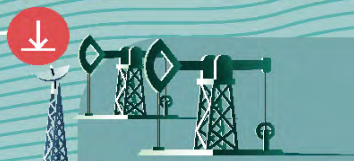

# SATELLITES FOR DIGITAL ECONOMY

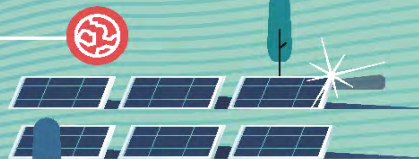

rsccl.ru



## Igor Kot, Deputy Secretary-General Gazprom Space Systems

***Igor Kot, Deputy Secretary-General of Russia-based satellite operator Gazprom Space Systems, shares his insights on how their company has weathered the global pandemic and their plans moving forward as they celebrate their company's 30th anniversary in 2022.***

***How has the global COVID pandemic affected your business and how did you cope as a company to the challenges?***

Since 2020, the situation in the satellite telecommunication industry, as in the entire global economy, has become more complicated due to Covid-19. According to quarterly reports provided on satellite operators' websites, the majority of publicly listed operators stated a continuing decrease in revenues for the three quarters of 2021. Prior to the crisis, forecasts of the leading analytical companies (such as Euroconsult and NSR) assumed in 2020 a return to growth in total industry revenue, which has been declining since 2015. But due to the impact of Covid-19, this return to growth is now being delayed until at least 2022. The impact of Covid-19 varies significantly depending on the vertical of the satellite communications market. Mobility segment suffered the most – air and maritime connectivity, where the consumption of satellite services decreased dramatically. Other data applications, such as consumer broadband and cellular backhaul, have suffered less and are expected to see a gradual increase in capacity demand with 12-18 month delay over previous forecasts.

The market crisis phenomena has made its own adjustments to the business activities of Gazprom Space Systems (GSS). During the pandemic, some areas of the satellite business have been undergoing serious changes, satellite capacity fill rates and amount of services have decreased, thus it made difficult to maintain stable the monthly proceeds from preliminary contracted satellite capacity and services still being valid in 2020-21. Therefore, in order to cope the challenges and make up for such gaps, GSS maintains the required volume of income by attracting new customers. In addition, the company had to improve the operational efficiency and reduce some costs. This enabled GSS not just to maintain the



**Igor Kot**

appropriate level, but to demonstrate revenue growth for the last two years.

***How you see your company moving forward post-pandemic?***

The efforts mentioned above helped to balance the



# C- & KU-BAND CAPACITY FOR THE EASTERN HEMISPHERE

Yamal-601 (49°E) Yamal-402 (55°E) Yamal-401 (90°E) Yamal-300K (183°E)

The wide coverage areas of Yamal satellites enable communication services delivery to different parts of the world for the purposes of Oil & Gas, Government, Aviation, Maritime, Education and Emergency segments. Yamal Satellite Capacity is successfully used for communication links and data transmission, TV distribution, occasional use, trunking, backhaul, inflight and maritime connectivity.

[WWW.GAZPROM-SPACESYSTEMS.RU](http://WWW.GAZPROM-SPACESYSTEMS.RU)





**A scale model of Gazprom Space System's Assembly, Integration and Test Facility (Gazprom AIT) slated for completion in 2022. Located at Gazprom's Telecommunication Center outside of Moscow, it will be the first integrated facility in Russia for the assembly and testing of satellites.**

business in this unstable environment for a while. Obviously, it is not enough over the long run. Operators are seeking their own business recipe, but in general the approaches are very similar. Firstly, all satellite operators endeavor to make the most of the capacity on existing orbital assets (basically traditional communication satellites with wide coverage areas, in C- and Ku-bands), where they had had solid investments. The decline in market prices for satellite capacity forces many fleet operators to strengthen vertical integration and develop managed services combining the lease of satellite capacity, teleport services, ground segment equipment support, etc. This approach reduces the risks of falling into the so-called "raw capacity trap". Some players say they are trying to get rid of the silo mentality existing among satellite operators and not positioning themselves as some independent unit, but act as partners to large telcos and cooperate more actively with terrestrial networks. Increasing customer focus, building partnerships, as well as developing projects of capacity sharing with terrestrial wireless network operators – a set of options GSS will continue to leverage for further development. In addition, the company is going to extend its Ka-band business by complementing Yamal-601 coverage with new HTS satellite Yamal-502 designated to increase services provision in such applications as broadband, IFC, Maritime, etc.

***"...Increasing customer focus, building partnerships, as well as developing projects of capacity sharing with terrestrial wireless network operators—a set of options GSS will continue to leverage for further development. ..."***

*What are your key targets for the company in 2022?*

There are several high-profile events in GSS' agenda for the next year. In terms of existing GEO satellite fleet development, GSS is going to step up to the investment phase of the Yamal-501 project on its way of Yamal-402 scheduled replacement. As for Earth Observation (EO) business, GSS will continue the development of aerospace monitoring system-SMOTR. The system will allow solving a wide range of industrial and environmental problems as well as provide monitoring of infrastructure facilities, in particular including enterprises of Oil & Gas sector. In addition, we will be completing the construction of the first in Russia, Assembly, Integration and Test Facility (Gazprom AIT).

*What else can we expect from Gazprom Space Systems in the coming months?*

In 2022 GSS is going to celebrate its 30th anniversary. Thirty is fairly a considerable and conscious age, when the company has a huge experience in successful projects implementation behind and still has a strong appetite to evolve notwithstanding the challenging economic situation. Being a long-running player in satellite industry GSS will continue activities towards cooperation and partnerships for the benefit of the global space economy on its road to post-pandemic recovery. 



# We have taken Summit to new heights



Kilowatts of  
Solid State RF



Highest  
Availability



Lowest  
MTRR



No Single Point  
of Failure



Available in C, X,  
Ku and S-Band  
Architectures

## INTRODUCING SUMMIT II

The **Summit II** high-power, modular, soft-fail redundant SSPA systems are wide bandwidth and ruggedized for outdoor applications. They can be configured with 4, 8 or 16 amplifiers and are field expandable. All of the amplifiers are phase combined into a single system that can generate extremely high levels of RF output power – 10,000 watts or more.

To learn more about the **Summit II** high power systems, visit [advantechwireless.com/summit-II/](http://advantechwireless.com/summit-II/)



**ADVANTECH**

**Wireless Technologies**

[advantechwireless.com](http://advantechwireless.com)

# In Skynet We Trust

by Robert Bell

In the Terminator films, an artificial intelligence system called Skynet is put in charge of the US nuclear deterrent. After some consideration, it reaches the not-unreasonable conclusion that human beings are dangerous. Cue Armageddon, followed by a long mopping-up operation to ensure that humans will never pose a threat to a world now run by machines.

Something similar is happening in satellite ground segment – but the ending is much, much happier. After years of piecemeal adoption, today’s teleports are going all-in on automation and orchestration – and making major gains in quality of service, productivity and value-add to customers. WTA recently published a report, Service Automation and Orchestration for Teleport Operators, that tells the story in detail.

## Automation and Orchestration

In an earlier report published in 2018, Automating the Teleport, WTA found that control of pointing, frequency, power, polarization and other satellite communications basics already had been moved from manual control to network management systems. Manual payout was transitioning to content management and scheduling systems. The teleport was in the process of being transformed from the traditional antenna farms into data centers with dishes that layer on value-added capabilities and services. Today, both automation and orchestration are well established and growing among teleport and satellite operators

Automation, a staple of networks operations for decades, means completing a single task or function without human intervention. Incorporating automation into a network can improve the performance and efficiency of time-intensive, manual processes, reduce staff workload, remove the risk of human error and drive down costs for network operators.

“Automation has played a huge role in providing services to broadcast customers and supporting mission critical data operations for years,” a teleport operator executive told us. “This automation can be as simple as making sure that, in the event of a fiber break, the con-

tent is switched to a redundant network path immediately with no noticeable interruption of services. More recently, automation has provided the ability to remotely monitor networks, enabling operators to have full visibility into what is happening across the entire

network from a single location rather than having control rooms in various facilities spread around the globe.”

At the same time, growing customer demands are driving teleports to improve their use of automation. The next step for many is orchestration, the process of linking together a series of automations. This can mean not just deploying an application but also integrating it into the network so it can immediately communicate with other applications and end users. Orchestration is more complex than automating a single task, but the benefits can also be exponentially greater for both operators and their customers, expanding the ability to bring new services and new opportunities to the market.

“The world is changing very fast,” a satellite operator executive said. “The mindset of the customer has changed in the last few years. For a satellite company, where major changes have taken 10 to 15 years, the change that we’ve had is amazing. People and their technology are more networked, and there is more remote work. A few years ago, there was no need to have return capacity, just forward. Now everyone needs the internet connected to their house.”

“I remember distinctly, five years ago, that customers already wanted much more dynamic ability to request

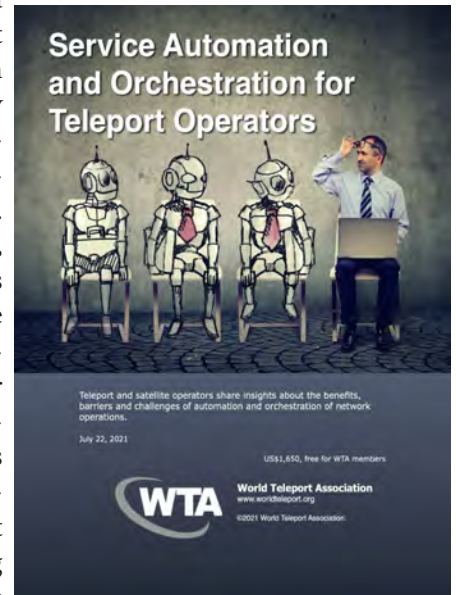



bandwidth,” a service provider executive said. “They wanted to change their CIR [committed information rate] levels on the fly. Today, with automation, it’s much easier to support these types of requests. We can increase the bandwidth for a customer for a week, and if you can automate the process, it makes it easier to handle that customer request, especially for customers that are moving around.”

“The ability to automate and the benefits it provides teleport operators have improved immensely throughout the past five years,” said a teleport operator executive. “It’s easier to get the network management systems preconfigured to an entire service. Before, we had to go to subsystems, but automation now is an entire service as opposed to a subsystem within the service.”

### Going Faster

The growth in satellite capacity that drove these automation improvements continues today at an even faster pace. The teleports that link the terrestrial and space segment are being asked to provide more services for more customers. Some are traditional users that understand the complexity of the teleport. Others are of a new breed of customer that do not need to understand what is happening behind the scenes and only care that the teleport operators provide uninterrupted, high-quality services.

The move to orchestration is also a priority due to the large amount of collected data and analytics. High-value services, such as overall network availability, are the initial targets of orchestration, but the ultimate goal for most teleport operators is incorporating every aspect of service management into an orchestrated architecture. Among the areas being addressed are improving the customer experience to create an environment which anticipates and reacts faster to any customer need or service issue. Customers experience improved flexibility of operations and more competitive services, while employees gain from efficiency in processes and reduction in manual work. Leveraging orchestration will enable teleport and satellite operators to be the engine of continuous change for their customers.

### The Human Factor

The value that the engineers bring to the automation and orchestrations process may be why most of the companies in the sector do not see investments in these areas

***“...The ability to automate and the benefits it provides teleport operators have improved immensely throughout the past five years...”***

as leading to headcount reductions. A commonly shared view among executives is that increased capabilities in these areas will free up their skilled workers and highly trained engineers from having to focus on tedious tasks.

“In a service company, this vision is less diffused than in a manufacturer company,” a satellite operator said. “The improvement of the quality of the operative worker is appreciated and shared. The people have clear day-by-day evidence on how the interaction with the customers is faster and more accurate than in the past.”

As the customers expect more from their teleports and networks, and advanced layers of service and new businesses are introduced, these employees will be required for more critical projects. In many cases, the introduction of new technology and more advanced orchestration processes may even require further investment in employees and advanced training to meet the needs of end users.

“Any automation we’re putting into the system is freeing up resources, not eliminating,” a technology executive said. “We’re not doing automation to remove headcount. We’re doing automation to alleviate some of the tedious tasks that allow the team to do more important things, like times they have to walk around the facility and check the fuel level in a generator or levels on the batteries. All the automation allows them to install new services and update hardware platforms and make sure we have the latest patches on the software systems. They are doing more customer-facing work.”

“We’re a constantly growing company,” a satellite operator said. “As far as I know, we haven’t had a headcount reduction in more than a decade or 20 years. I think our employees are pretty comfortable knowing they won’t be replaced by a robot any time soon. Our employees understand if they bring forth improvements, they are not automating themselves out of a job. There will be more work to automate, especially the mundane tasks or repetitive tasks, but rather than being replaced, the employees can move on to doing value-added work.”

And so, trusting in Skynet in this real-life movie has

a surprise ending. The companies, customers and employees all win – and the decades-old teleport business strengthens its competitive advantage in a global marketplace.

**Use Cases for Orchestration**

- A teleport operator is helping reduce the digital divide in a country and orchestration is streamlining the interactions along the supply chain.
- It is improving the efficiency of capacity reservation systems, helping customers share transponder space across different service needs.
- Orchestration is helping teleport operators incorporate satellite capacity into their networks as the sector brings more high-throughput satellites online and the operations model transitions from hub-and-spoke operations to spacecraft that provide services via multiple spot beams.
- Orchestration is allowing for setting up broadband networks more quickly and efficiently in parts of the globe that are underserved or unserved.
- It enables demanding but infrequent users, such as

yacht owners and operators, to have direct control of the levels of service provided to end-users depending on rates of demand. 🇺🇸



**Robert Bell** is Executive Director of the World Teleport Association, which conducts research into the teleport and satellite industry and offers a Teleport Certification program to service providers.

**Service Automation and Orchestration for Teleport Operators is available for free to members and for sale to non-members at:**

<https://www.worldteleport.org/store/viewproduct.aspx?id=18711387>

**A webinar based on the report is available free on demand at:**

<https://www.worldteleport.org/general/custom.asp?page=Webinars>

# Advance the future



AUTOPED  
First motorized scooter  
**1915**



Our task is not to foresee the future, but to enable it.

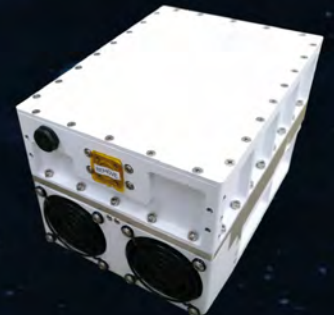

ACTX-Ka40W-E31-V5  
BUC Ka-band 40W dual band (29-31 GHz)  
**2021**



# sat-nms Monitoring & Control System

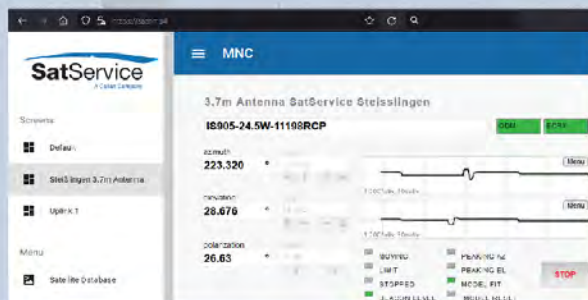
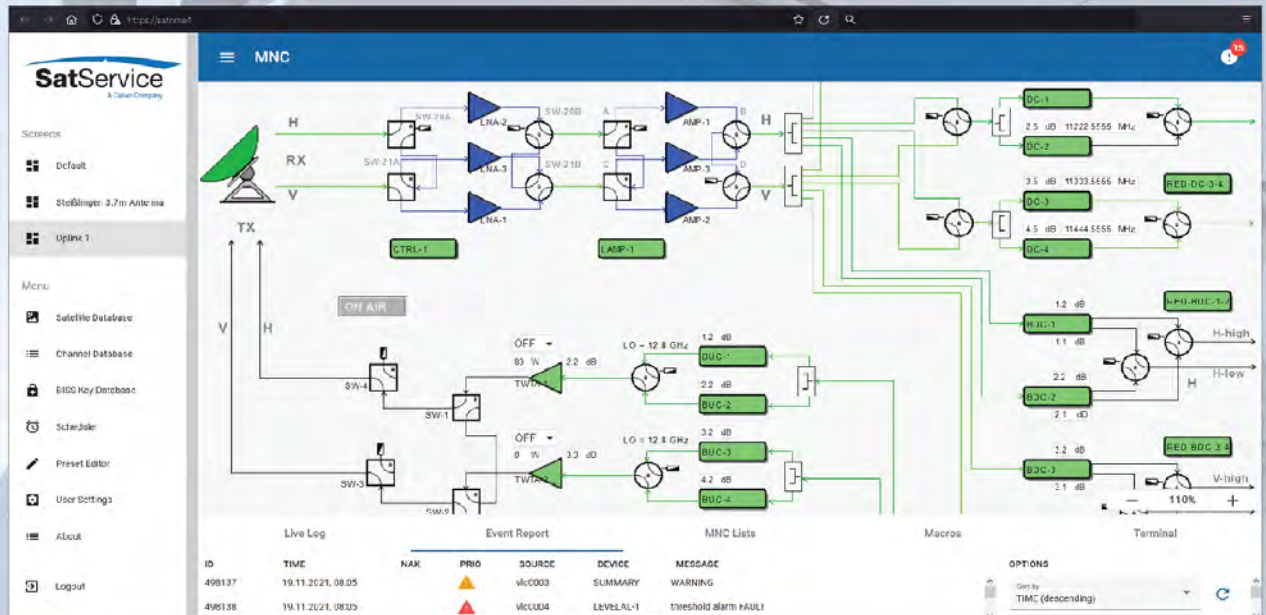

- web browser client
- easy re-configuration
- operator friendly GUIs
- smart work flows
- vendor independent

**IF YOU HAVE ANY QUESTIONS OR NEED A DEMO  
PLEASE SCHEDULE A PHONE OR VIDEO CONFERENCE WITH US.**



## 1.35M FIT

FLEXIBLE INTEGRATED TERMINAL

MANUAL POINT  
OR AUTO-ACQUIRE FLYAWAY  
TRI-BAND CONFIGURABLE

AvL's 1.35M FLEXIBLE INTEGRATED TERMINAL IS A FULL-FEATURED TRI-BAND (X, KU OR KA) TERMINAL WITH A COMPACT PACK-UP INTO 2 IATA CHECKABLE CASES.

Operated manually or motorized with auto-acquire, the terminal's optional AvL antenna control system automatically acquires and tracks satellite beacons with an internal receiver. The antenna is ODU and modem agnostic, and optionally provided with multiple modem options.

- ◆ Tri-band: X-, Ku- or Ka-band wideband
- ◆ Configurable with Ka-band certified modems
- ◆ Axisymmetric 1.35m 12-piece carbon fiber reflector
- ◆ AvL Cable Drive pedestal with integral base and tripod
- ◆ High-wind stability kit
- ◆ Quick band changes & multiple RF packages available
- ◆ Standard 2-port feeds & optional 3-port
- ◆ Pre-configured SSPA/LNB kits
- ◆ Optional AvL terminal power supply





## AvL Technologies

AvL antennas are the industry benchmark of excellence for defense and homeland security, GEO and MEO ground systems, disaster relief, mobile broadband Internet access, oil and gas data backhaul, and satellite news gathering (SNG).

Satellite News Gathering, or SNG, antennas are more precise and robust than Mobile Broadband VSAT antennas due to the requirements for streaming high definition video. AvL Technologies provides the most comprehensive range of SNG antenna apertures, ranging in size from 85cm to 2.4m, and broad capabilities for operating with high-power amplifiers (HPAs) for high data rates. AvL also offers the most extensive range of broadcast frequency bands in the industry, including C, Ku, DBS and Ka. AvL's SNG antennas can be mounted to a vehicle or packed and shipped in cases.

For more information, please visit [www.avltech.com](http://www.avltech.com)



**AvL's new 2.4m Axi-Symmetric, Auto-Acquire Antenna**

## Walton De-Ice Systems

**W. B. Walton Enterprises, Inc.** AKA Walton De-Ice has been the satellite industry leader in Earth Station Antenna De-Ice systems for over 40 years. Beginning with our flagship, Hot Air Plenum De-Ice as the most economical and efficient method of keeping snow and ice from accumulating on antennas ranging in size from 3.7 meter up to 32 meters.



As the industry has evolved and antenna size requirements became smaller Walton De-Ice has lead the way in providing methods of signal protection such as our patented Snow Shield and Ice Quake/Rain Quake for antennas ranging in size from 0.65 meter up to 6.5 meters. Available in heated or passive solutions, when considering budget and operating budget no other method of antenna de-icing compares in cost and efficiency.

With the emergence of LEO Tracking antennas and mobile solutions the Walton Portable Radome has no competition when protecting terminals from weather such as rain, snow, ice, heat or blowing sand. Virtually invisible to RF and the ability to withstand wind up to 85 MPH/137 KPH

For more information, go to: [www.de-ice.com](http://www.de-ice.com)

## RF-Design's Premium class RF-over-Fiber systems

RF-Design's FiberLinkplus series incorporates non-redundant, 1+1 redundant as well as N+1 and N+2 redundant RF-over-Fiber systems thus ensuring a stable signal transmission via optical fiber at any time. Different outdoor enclosures and 19" indoor rackmount chassis allow a population with up to 32 TX and/or RX modules covering various frequencies (950 - 2150, 850 - 2450MHz, 50 - 3200MHz, 40 - 200MHz and 10MHz) ready for operation at nearly any environment. The FiberLinkplus systems come with a high-density modular design, excellent quality and performance as well as many included features, such as:

- 1RU/19" to 4RU/19" rackmount chassis or appropriate outdoor enclosures
- Suitable for outdoor and indoor applications
- Ready for non-redundant or redundant operation
- Supports various RF frequencies (950 - 2150, 850 - 2450MHz, 50 - 3200MHz, 40 - 200MHz and 10MHz)
- Allows mixed TX/RX population e.g. for uplink and downlink applications
- Variable gain control, RF power monitoring, Switchable LNB-supply
- Hot swappable optical modules
- Front panel measurement port -20dB
- Beneficial signal and status monitoring functions
- Local configuration and monitoring (LC-Display or touchscreen)
- Remote configuration and monitoring (WebGUI, SNMP)

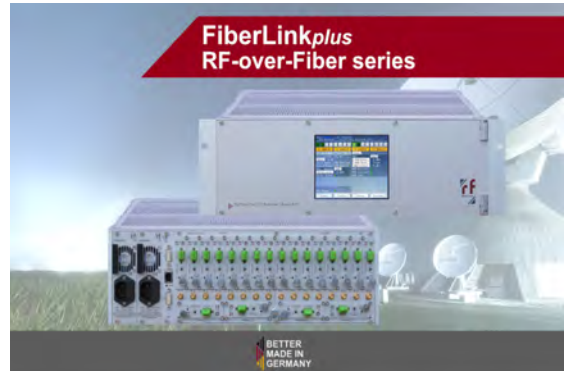

For more information, go to: <https://rf-design-online.de> or email [contact@rf-design-online.de](mailto:contact@rf-design-online.de)



designed for perfect signals

## Excellence in RF Equipment

### "FlexLink K4" 32:32 Switch Matrix



### "QLink" Quad RF-over-Fiber System



### "HQR445C" N+1 redundant Line Amplifier



### "PwrMxG" Dual RF Power Meters





## ND Satcom's Multi-Band Flyaway Terminal MFT 1500

ND SATCOM continues to distinguish itself through its commitment to innovation and customer satisfaction. The coming launch of the ND SATCOM FLYAWAY terminal underscores the company's competitive advantage.

One advancement that sets this new terminal apart is its operational wind resiliency: it can withstand and function in very high wind speeds and during severe storms.

ND SATCOM incorporated another clear advantage: the latest version of the premier SKYWAN 5G technology. Customers value the proven high reliability and security that SKYWAN represents. The bar was raised here, too, by integrating the pioneering innovation of Adaptive Coding and Modulation (ACM) for TDMA, thus permitting transmission during heavy rains with adaptive bandwidth control. For the motorized FLYAWAY version, engineers integrated the ACU into the 5G modem, thus minimizing equipment and enabling pointing on SKYWAN or DVB signals.

ND SATCOM pushed the engineering boundaries further by optimizing portability and product longevity for this new FLYAWAY. Carbon was used wherever possible to reduce weight, enhance durability, and provide the extreme stiffness required for Ka-band in high wind conditions. Both the unique 180° azimuth range and integrated feed-booms for various bands expedite setup and use. For an extremely fast setup -, this terminal was designed for easy deployment and dismantling - time and again - while maintaining structural integrity throughout.

The in-house R&D team in Germany designed and developed the new terminal, rigorously field testing the finished product as well as testing against stringent standards for military products. ND SATCOM FLYAWAY is ready to go: whenever, wherever you are. For more information, go to: [www.ndsatcom.com](http://www.ndsatcom.com)



## Jonsa Technologies

Jonsa Technologies from Taiwan is a trustworthy manufacturer of communication antennas, and our monthly production capacity has been over one million in a variety of antenna products. We are waiting for the new partner who cooperates with us and creates the win-win situation together.

The best-selling product in Jonsa includes:

### 0.6M/0.9M Auto and Manual Flyaway

- Ring focus antenna with 8 segments reflector
- Support Ku and Ka band as an option
- Carbon fiber reflector with light weight, high strength and one person can finish the installation within 3 minutes.

### VSAT (E74/97/120) antenna

- Customized VSAT antenna products
- Correspond with electronic devices, such as integrated LNB and Feedhorn
- Support Ku and Ka band as an option

### 0.6M/0.9M Ka and Ku band Maritime with radome

- One-touch commissioning
- High gain and carbon fiber antenna
- Support beacon receiver, DVB, and digital tracking system



For more information, please visit [www.jonsa.com.tw](http://www.jonsa.com.tw) or email [saccount@jonsa.com.tw](mailto:saccount@jonsa.com.tw).

## Trending: A Year to Remember and A Year Ahead

by **Martin Jarrold**

As I began writing this column news was filtering over media about the decision of the World Health Organization to designate the latest mutations to the spike protein of the Sars-Cov-2 virus as a “variant of concern”, and to use the Greek letter Omicron to name it (rather than the original designation of B.1.1.529). Thanks to the skills of scientists at South Africa’s Medical Research Council Genomics Centre the exact sequencing of the new variant was speedily completed and its details promulgated quickly to their colleagues

in sister agencies around the world. News of cases of infection with Omicron was already headlining to include instances way beyond southern Africa; in Israel, Hong Kong, and Belgium. The next day, the UK notified its first two cases. Over following days cases were reported elsewhere around the world.

This news, to a certain extent, colors my contribution this month. Habitual at this time of year is the

practice of appraising the events of the last 12-months. This is partly as precursor to embracing our expectations for the prospect of events in the coming year, both in general terms and in terms of events within, and impacting, the satellite industry. This tendency is understandably strengthened by a year of pandemic circumstances which have exacerbated our reliance on connectivity.

Against this general backdrop –

# GVF

Satellite. Solutions. The World.

stakeholder dialogues on the current state of the satellite communications industry and its user markets in respect of a swath of interconnected trends engendering transformational changes in the industry, changes

that are additionally serving to catapult satellite into a more central position in our everyday lives.

‘Satellite Industry Trends: A Year to Remember, A Year Ahead’ (<https://gvf.org/webinar/satellite-industry-trends-a-year-to-remember-a-year-ahead/>), moderated by Stéphane Chenard of Euroconsult, assembles a panel of industry experts from across antenna technologies; communications and IT service provision; modem/network management systems/infrastructure technologies; and NGSO constellation operations. Providing penetrating analysis and insight, along with the complementary perspectives of orbital and

**Satellite Industry Trends: A Year to Remember, A Year Ahead**

GVF SATELLITE Webinars Series

**MODERATOR**

Stéphane Chenard  
Senior Consultant  
Euroconsult

**PANELISTS**

David Fotheringham  
Director Product Management  
Kymeta

Will Mudge  
Vice President  
Engineering Operations  
SpeedCast

Jo De Loer  
VP Market Development  
and Strategy  
ST Engineering |Direct

Chris McLaughlin  
Chief of Government,  
Regulatory and Engagement  
OneWeb

Sponsored by **KYMETA**

WATCH REPLAY

and as we move towards and into the 5G era, acknowledging (as will the 3GPP Release 17 document due for publication in the first quarter of 2022) that the near-future “network of networks” is the highly significant opportunity that the world has to completely leverage the advantages to be derived from additional use cases for satellite communications – the GVF webinar of December 1st investigates the nature of industry

and as we move towards and into the 5G era, acknowledging (as will the 3GPP Release 17 document due for publication in the first quarter of 2022) that the near-future “network of networks” is the highly significant opportunity that the world has to completely leverage the advantages to be derived from additional use cases for satellite communications – the GVF webinar of December 1st investigates the nature of industry



**Protect Your  
Earth Station Antennas  
From Ice, Snow, Rain, and more**

**WALTON**  
**DE-ICE**



**WINTER  
IS  
COMING  
ARE YOU READY**

**Antenna De-Ice Systems:**

- **HOT AIR**
- **Ice Quake**
- **Snow Shield**
- **Portable Radome**

**Walton Advantages:**

- **Uniform surface heating**
  - **Minimizes reflector distortion loss**
  - **Maximizes accuracy**
- **Most powerful and cost-effective system on the market**
- **40+ years field-proven leadership**
- **24/7/365 Support & Field Services**

+1 (951) 683-0930 | [sales@de-ice.com](mailto:sales@de-ice.com) | [www.De-Ice.com](http://www.De-Ice.com)

W.B. Walton Enterprises, Inc. P.O. Box 9010 San Bernardino, CA 92427, USA

ground segment, the webinar features, from Kymeta, David Fotheringham, Director Product Management; from Speedcast, Will Mudge, Vice President, Engineering Operations; from ST Engineering iDirect, Jo De Loor, Vice President, Market Development & Strategy; and from OneWeb, Chris McLaughlin, Chief of Government, Regulatory & Engagement.

From a ‘big picture’ perspective the webinar looks at the justification, across both space and ground segments, for describing 2021 as “transformational”, defining the trends setting it apart from previous years and those being primarily responsible for propelling the satellite industry into that more central position in our everyday lives.

To begin with each panelist is asked to briefly discuss their top event of 2021, and expected/predicted top event for 2022.

COP-26 – the United Nations Climate Change Conference 2021 – celebrated as something of a success by some, condemned as a failure by others, including many of the developing nations likely to be most severely impacted by climate change, has nevertheless positioned global warming as impossible to ignore or dismiss; positioning it as the background to everyday operations for at least some of the satellite industry’s user market verticals. This webinar asks where satellite communications fits into this “Problem #1” for current and future generations. Our industry does, of course, have its own ecosystem/environment concerns, and this dialogue asks if 2021 will be remembered as the year when space debris was finally taken seriously.

The discussion also looks at the impact of transformational change to the business context of space,

**“...Some of these pending questions are: Where to next? What precise direction is indicated on the roadmap of the nation’s space landscape?...”**

both strategically for the entire sector and at the scale of the individual company, both corporates and start-ups. Various business trends – variously precipitated by the dynamics of the pandemic (of which the Omicron variant is the latest development) on national and global economics – are of significance, for example, changes in interest rates affecting industry consolidations, increasing commodity prices, and supply-chain problems, particularly with semiconductors.

It is clear that recent years have witnessed some significant trends in vertical integration in the satellite industry. More recently we have seen innovative investment relationships within and across industry segments, such as investments in OneWeb by Hughes and Eutelsat. Very recently, a major acquisition was announced with the Viasat-Inmarsat deal. Against this backdrop the webinar panelists are asked to reflect on trends that seem to include a new mega-constellation project announcement every week, asking “Should we be excited? Should we care? Should we worry?”

The advent of the mega-constellation has, of course, been built upon remarkable advances in R&D, as well as in manufacturing innovation. The panel considers whether anything that was technically beyond the state-of-the-art a year ago

became possible during 2021, and enquires as to what they anticipate for imminent breakthroughs in 2022.

Going into 2022 brings us closer to WRC-23, when the member nations of the ITU are scheduled to gather once again to decide how the physical world’s limited spectrum resources are allocated. The panel of ‘Satellite Industry Trends: A Year to Remember, A Year Ahead’ is asked their views as to whether they think there were any remarkable regulatory developments in 2021, and any awaited in 2022.

Any discussion of spectrum issues inevitably leads us back to the subject of the 5G era and the panel members provide their appraisal of how much it had matured in 2021. As noted above, with 3GPP Release 17 expected in early 2022, the key question to be answered had to be “What will it change?”

If you didn’t get the chance to join the webinar audience “live” you haven’t entirely missed out. You can catch-up with GVF’s on-demand recording of the event, sponsored by Kymeta, through our website at <https://gvf.org/webinar/satellite-industry-trends-a-year-to-remember-a-year-ahead/>. Until 2022, stay safe!



Martin Jarrold is Vice-President of International Program Development of GVF. He can be reached at: [martin.jarrold@gvf.org](mailto:martin.jarrold@gvf.org)



## Rocket Lab Acquires Planetary Systems Corporation

Denver, Colo., December 2, 2021--Rocket Lab acquires space hardware company Planetary Systems Corporation (“PSC”). Crux CFO Advisors was the exclusive financial advisor in the transaction.

PSC was founded in 1998 to provide high-quality, affordable mechanical systems to the aerospace industry and brings to Rocket Lab unparalleled leadership in separation systems and satellite dispensers. This, combined with their flight-proven, cost-effective, and lightweight hardware, has streamlined the process of attaching satellites to rockets and releasing them in space while ensuring they’re protected during the journey to orbit. PSC’s expertise is complementary to Rocket Lab’s vertically-integrated Space Systems division and its own

in-house manufactured and operated Photon spacecraft line, Maxwell satellite dispensers, satellite components, and mission flight software by Advanced Solutions, Inc.

Both organizations have combined for more than 200 missions. Rocket Lab’s acquisition of PSC brings together



two experienced space organizations that further strengthens Rocket Lab’s end-to-end space offering across the full launch and satellite spectrum.

As reported at the time of acquisition,

the deal enables PSC to make use of Rocket Lab’s resources and manufacturing capability to grow their already-strong commercial hardware trade and continue serving their existing satellite customers launching spacecraft on other launch vehicles. PSC’s team of 25 people will continue to be led by the company’s President and CEO Mike Whalen in Maryland, with founder Walter Holemans also remaining in his role of Chief Engineer.

This is Crux’s second space industry sell-side M&A deal in less than a year. Crux was previously the CFO advisor to Blue Canyon Technologies, which was sold to Raytheon in December 2020 for US \$432 million.



## Voyager Space Announces Intent to Acquire Majority Stake in Space Micro

Denver, Colo., November 22, 2021-- Voyager Space Inc. announced its intent to acquire a majority stake in San Diego-based Space Micro. Space Micro is a highly innovative engineering-driven business focused on advancing high-performance satellite communications, digital, and electro-optical systems with over 2.7 million hours of space flight heritage.

Space Micro developed the world’s highest data rate Laser Communications Terminal in orbit. As part of the agreement, Voyager intends to provide strategic operations support to help advance Space Micro’s technology throughput to civil, commercial, and defense customers.

“For almost two decades Space Micro has developed game-changing technologies and provided trusted high-performance satellite communications systems,” says Space Micro Co-Founder and Chairman, David Strobel. “Today marks a huge step in our growth trajectory. The satellite constellation market stands at the tipping point of explosive expansion and now, with the Voyager team and operational functions by our side, we will be prepared to scale our technologies to meet these market needs.”

Founded in 2002, Space Micro delivers best-in-class satellite technology to the growing commercial market. Space Micro delivered its first computer and image-processing subsystem in

space within the first four years as an organization, then went on to develop its first advanced Software Defined Radios for NASA’s Interface Region Imaging Spectrograph (IRIS), Lunar Atmosphere Dust and Environment Explorer (LADEE), and The Transiting Exoplanet Survey Satellite (TESS). Today, the company has multiple active contracts with NASA, including the development of real-time data sorting inference processing units (IPUs) for Earth observation missions and for providing X-band transponders for two lunar missions selected under the Artemis program. Space Micro also has a long history in providing critical technology for the U.S. Department of Defense, including Intelligence, Surveillance and Reconnaissance (ISR) space payloads, laser secure communications terminals, and digital RF-to-optical and optical-to-RF signal converters.

Space Micro’s customers include NASA, the U.S. Space Force, U.S. Air Force, Space and Missile Center (SMC), U.S. Special Operations Command (SOCOM), Space IL (recipient of the Google X-Prize Moonshot Award), the German Space Agency, and many more. Most recently, Space Micro was awarded a contract to deliver ten Nanocom™ Software Defined Radios via Lockheed Martin in support of the Space Development Agency’s Tranche 0 satellite constellation.



# Perfect Bundles for Next Gen HTS & VHTS Systems!

WORK Microwave's Industry Leading  
Frequency Converters and Modems

Meet us virtually  
at IBC Digital!

**Q/V-Band Converters:**  
unparalleled performance,  
reliability and flexibility

**All-IP Platforms:**  
wideband modems for  
up to 500 Msp/s





## SSPI Names CEO of Hellas Sat and Projects of Speedcast and UltiSat as Recipients of the 2021 Better Satellite World Awards AC Clyde Space

London, UK, November 18, 2021—The **Space & Satellite Professionals International** announced the recipients of the seventh annual Better Satellite World Awards. The awards honor established companies along with disruptive innovators who make the world a more prosperous, healthier, better-educated, sustainable and inclusive home for humankind.



**Christodoulos Protopappas**

An international jury selected Hellas Sat Founder and CEO and humanitarian **Christodoulos Protopappas**, Speedcast and Willka Yachay's project to bring satellite connectivity to the Q'eros tribe in Peru and UltiSat's services for the UN in the Democratic Republic of the Congo to receive this year's awards.

The recipients will be honoured at the Better Satellite World Awards Virtual Celebration on 9 December and a live reception on 10 January 2022 in London.

"In a time of profound disruption and crises at nearly every level of human society, the space and satellite community is providing indispensable support and relief to remediate suffering and to improve and preserve what is best in human culture," said SSPI Director of Development and Innovation Louis Zacharilla. "Most important, it is pushing us toward a time when things inevitably will get better," he added.

The selection of the recipients for the Better Satellite World Awards was made by an international jury consisting of a broad cross-section of industry thought leaders and distinguished professionals.

Also at the Celebration, the SSPI UK Chapter will present its sixth annual Satellite Personality of the Year Award to Volodymyr Levykin, Founder and CEO of Skyrora for his many contributions both personally and through the company to Edinburgh's robust and growing satellite industry.

The Better Satellite World Awards Celebration is produced by SSPI and its UK and Isle of Man Chapters.

## Rocket Lab Appoints Andrew Bunker as VP of Government Operations and Business Strategy

Long Beach, Calif., November 9, 2021 – **Rocket Lab USA, Inc.** (Nasdaq: RKLB), a launch services and space systems company, announced the appointment of **Andrew Bunker** to the role of Vice President of Government Operations and Business Strategy, effective November 8, 2021.

Bunker will be primarily responsible for the development and execution of company's federal, state, and local government strategy. He will also play a leading role in strengthening Rocket Lab's engagement with industry associations. The appointment comes as Rocket Lab expands its end-to-end ecosystem footprint with the acquisition of flight software company Advanced Solutions Inc in Colorado, and also narrows down potential locations for a new production facility and launch site for the reusable, medium-lift Neutron rocket.

Bunker brings more than a decade of experience in legislative affairs and space regulation to the Rocket Lab team. Prior to joining Rocket Lab, he held the role of Director of Government Operations at United Launch Alliance (ULA). In this role, he was responsible for representing ULA before Congress on matters of



**Andrew Bunker**

importance to the company, including national security, civil, and commercial space. He also supported ULA's engagement on regulatory matters before various federal agencies. Prior to working at ULA, Bunker worked for House Speaker John A. Boehner, where he served in a variety of positions supporting legislative efforts and operations on the House Floor. He currently serves as the Marketing Chair of the Washington Space Business Roundtable and holds a Bachelor of Arts degree in Political Science from Wake Forest University.

## Holger Stuehrmann Named to GM- Microwave Products of Southwest Microwave

Tempe, Ariz., November 4, 2021—**Southwest Microwave, Inc.** announced the promotion of **Holger Stuehrmann** to general manager. Stuehrmann succeeds Don Bradfield, who was recently promoted to president of Southwest Microwave, Inc.

Stuehrmann joined the Microwave Products Division in 2014 as director of sales, managing worldwide sales and business generation activities. He has 30 years of experience in new product development and operational performance improvement in RF / mmWave solutions for defense, space and commercial sectors.

His previous experience includes director of business development and sales and business manager, microwave components at STC Microwave Systems, a division of Crane Aerospace and Electronics. He also spent 11 years with Paris-based TEMEX Components, first as vice president, sales and marketing, then as vice president of operations, North America.

Stuehrmann holds a Bachelor of Science in Electronics Engineering from City University of Applied Sciences, Hochschule Bremen, Germany.





# OPTIMIZE YOUR SATCOM TERMINAL

Reliable high-performance Intelligent BUCs backed by test data guaranteed by key performance indicators such as low phase noise, high linearity, & rated output power over temperature.

Explore all **IBUC** models at [TerrasatInc.com](http://TerrasatInc.com)



**IBUC 2**



New **IBUC 3**



## 2.9 Billion Still Without Internet Access According to the ITU

Geneva, Switzerland, December 1, 2021--New data from the International Telecommunication Union (ITU), the United Nations specialized agency for information and communication technologies (ICTs), showed that an estimated 37 per cent of the world's population – or 2.9 billion people – have still never used the Internet. The ITU report also revealed strong global growth in Internet use, with the estimated number of people who have used the Internet surging to 4.9 billion in 2021, from an estimated 4.1 billion in 2019. An estimated 37 per cent of the world's population – or 2.9 billion people – have still never used the Internet.

This comes as good news for global development. However, ITU data confirm that the ability to connect remains profoundly unequal.

Of the 2.9 billion still offline, an estimated 96 per cent live in developing countries. And even among the 4.9 billion counted as 'Internet users', many hundreds of millions may only get the chance to go online infrequently, via shared devices, or using connectivity speeds that markedly limit the usefulness of their connection.

"While almost two-thirds of the world's population is now online, there is a lot more to do to get every-

one connected to the Internet," said ITU Secretary General Houlin Zhao. "ITU will work with all parties to make sure that the building blocks are in place to connect the remaining 2.9 billion. We are determined to ensure no one will be left behind."

The unusually sharp rise in the number of people online suggests that measures taken during the pandemic – such as widespread

lockdowns and school closures, combined with people's need for access to news, government services, health updates, e-commerce and online banking – contributed to a 'COVID connectivity boost' that has brought an estimated 782 million additional people online since 2019, an increase of 17 per cent.

The 2021 edition of Facts and Figures, ITU's annual overview of the state of digital connectivity worldwide, shows the number of Internet users globally growing by more than 10 per cent in the first year of the pandemic – by far the largest annual increase in a decade.

Strong growth since 2019 was largely driven by increases in developing countries, where Internet penetration climbed more than 13 per cent. In the 46 UN-designated Least Developed Countries (LDCs), the average increase exceeded 20 per cent.

"These statistics show great progress towards ITU's mission to connect the world," said Doreen Bogdan-Martin, Director of ITU's Telecommunication Development Bureau, which oversees ITU's data and analytics work. "But a vast 'connectivity chasm' remains in the LDCs, where almost three quarters of people have never connected to the Internet. Women in LDCs are particularly marginalized, with roughly four out of every five still offline."

Many of these 'digitally excluded' face formidable challenges including poverty, illiteracy, limited access to electricity, and lack of digital skills and awareness.

"Digital solutions would be needed to re-energize sustainable development and help put countries back on track to meet the UN Sustainable Development Goals (SDGs) for 2030," Bogdan-Martin added.

"Unfortunately, the communities identified in the 2030 Agenda as most at risk of being left behind are the very same communities now being digitally left behind."



PROVIDES **TELEVISION, INTERNET, CORPORATE AND GOVERNMENT SERVICES** ACROSS THE MIDDLE EAST, NORTH AFRICA AND BEYOND.



### Es'hailSat Key Services Include



TV  
BROADCASTING



PLAYOUT



VSAT



MOBILITY  
SERVICES



TELEPORT SERVICES



CORPORATE  
NETWORKS



TELECOMMUNICATION  
SERVICES



GOVERNMENT  
SERVICES



[www.eshailsat.qa](http://www.eshailsat.qa)

**Es'hailSat** سهيل سات  
Qatar Satellite Company الشركة القطرية للأقمار الصناعية

*Space to deliver your vision*



## The Satellite Markets 20 Index™

Company Name	Symbol	Price			Price Change	
		December 7	52-wk Range		Last Month	From Jan 15
<b>Satellite Operators</b>						
Thaicom Public Company Limited	THCOM.BK	11.10	5.50	14.10	3%	21%
Eutelsat Communications S.A.	ETL.PA	11.15	8.93	13.42	-10%	19%
APT Satellite Holdings Limited	1045.HK	2.25	1.70	2.95	-4%	7%
Echostar	SATS	26.62	19.75	30.90	3%	8%
SES S.A.	SES.F	7.07	6.12	8.00	-9%	-7%
<b>Satellite Manufacturers</b>						
The Boeing Company	BA	210.61	188.00	278.57	-7%	-1%
Maxar Technologies	MAXR	28.31	25.41	58.75	1%	-43%
Lockheed Martin Corporation	LMT	339.99	319.81	396.99	-3%	-4%
OHB SE	OHB.DE	35.7	33.50	49.85	-4%	-19%
Honeywell International Inc.	HON	207.54	194.55	236.86	-5%	0%
<b>Equipment Manufacturers</b>						
C-Com Satellite Systems Inc.	CML.V	2.36	2.13	4.48	-9%	-13%
Comtech Telecommunications Corp.	CMTL	25.53	16.79	30.40	10%	14%
KVH Industries Inc.	KVHI	10.21	9.24	15.29	4%	-16%
ViaSat Inc.	VSAT	46.54	29.82	61.35	-19%	28%
Gilat Satellite Networks Ltd.	GILT	7.51	5.80	22.69	-12%	3%
<b>Service Providers</b>						
DISH Network Corporation	DISH	32.29	28.53	47.05	-29%	-1%
Globalstar Inc.	GSAT	1.34	0.31	2.98	-14%	51%
Telesat Corporation	TSAT	31.83	19.69	56.54	-39%	20%
Sirius XM Holdings Inc.	SIRI	6.18	5.75	8.14	-2%	6%
Trimble Inc.	TRMB	87.45	61.74	96.49	5%	26%

The Satellite Markets 20 Index™ is a composite of 20 publicly-traded satellite companies worldwide with five companies representing each major market segment of the industry: satellite operators; satellite manufacturers; equipment manufacturers; and service providers. The base data for the Satellite Markets Index is January 2, 2008 - the first day of operation for Satellite Markets and Research. The Index equals 1,000. The Satellite Markets Index™ provides an investment benchmark to gauge the overall health of the satellite industry.

INDEX	Index Value Index Value Dec. 7, 2021	Percentage Change last month	Percentage Change since Jan 15 2021
Satellite Markets 20 Index™	2,789.71	-7%	12%
S & P 500	4,688.29	0%	23%

© 2010-2021 Satellite Markets and Research, Satellite Executive Briefing and the Satellite Markets Index™ are trademarks of Synthesis Publications LLC. Synthesis Publications LLC is the owner of the trademark, service marks and copyrights related to the Index. This newsletter does not constitute an offer of an investment product. Satellite Executive Briefing makes no representation regarding the advisability of investing based on the information provided in the Satellite Markets Index™. All information is provided 'as is' for information purposes only and is not intended for trading purpose or advice. Neither Satellite Executive Briefing nor any related party is liable for any informational error, incompleteness or for any actions taken based on information contained herein.

## ADVERTISERS' INDEX

<b>ACORDE</b> .....26 www.acorde.com	<b>Walton Enterprises</b> .....33 www.deice.com
<b>Advantech Wireless</b> .....23 www.advantechwireless.com	<b>WORK Microwave</b> .....36 www.work-microwave.com 
<b>Application Strategy Inc.</b> .....3 www.applicationstrategy.com	
<b>ARABSAT</b> .....7 www.arabsat.com	
<b>AvL Technologies</b> .....28 www.avltech.com	
<b>Es'hailsat</b> .....40 www.eshailsat.qa	
<b>Gazprom Space Systems</b> .....21 www.gazprom-spacesystems.ru	
<b>IKO Media Group</b> .....11 www.ikomg.com	
<b>Jonsa</b> .....13 www.jonsa.co.tw	
<b>ND Satcom</b> .....17 www.ndsatcom.com	
<b>RF Design</b> .....30 www.rf-design-online.de	
<b>RSCC</b> .....19 www.rsc.ru	
<b>Satservice GmbH</b> .....29 www.satservicegmbh.de	
<b>Spacebridge</b> .....2 www.spacebridge.com	
<b>STN</b> .....5 www.stn.eu	
<b>Terrasat ns</b> .....38 <b>Communicatio ns</b>	
www.terrasatinc.com	



Read the latest news, analysis, market trends, executive moves and many more at:

[www.satellitemarkets.com](http://www.satellitemarkets.com)